

NOTE:
 GENERAL CONSTRUCTION
 TOLERANCE: ± 5 mm [± 0.2 "]
 INSTALLATION REQUIREMENT
 SPACE FOR MAINTENANCE
 ABOVE TOP OF THE CABIN ON
 THE INTERNAL SIDE:
 *MIN. 300 mm [11.81"]
 *RECOMMENDED 750 mm [29.53"]
 *if space does not meet the
 required specifications contact
 us to discuss alternatives

GENERAL DIMENSIONS TOLERANCE:
 ± 5 mm [± 0.2 "]

NOTE:
 *unit must be installed on to a level
 floor (suggested flatness tolerance:
 ± 1 mm)

FRONT VIEW
 EXTERNAL SIDE

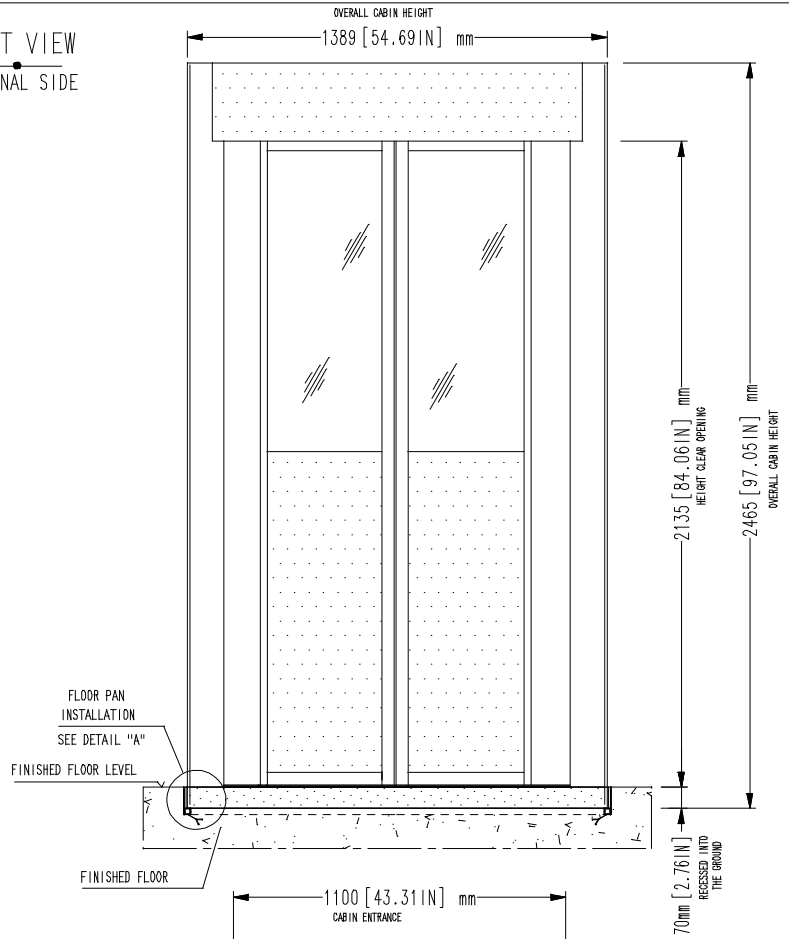

TOP VIEW
 INTERNAL SIDE

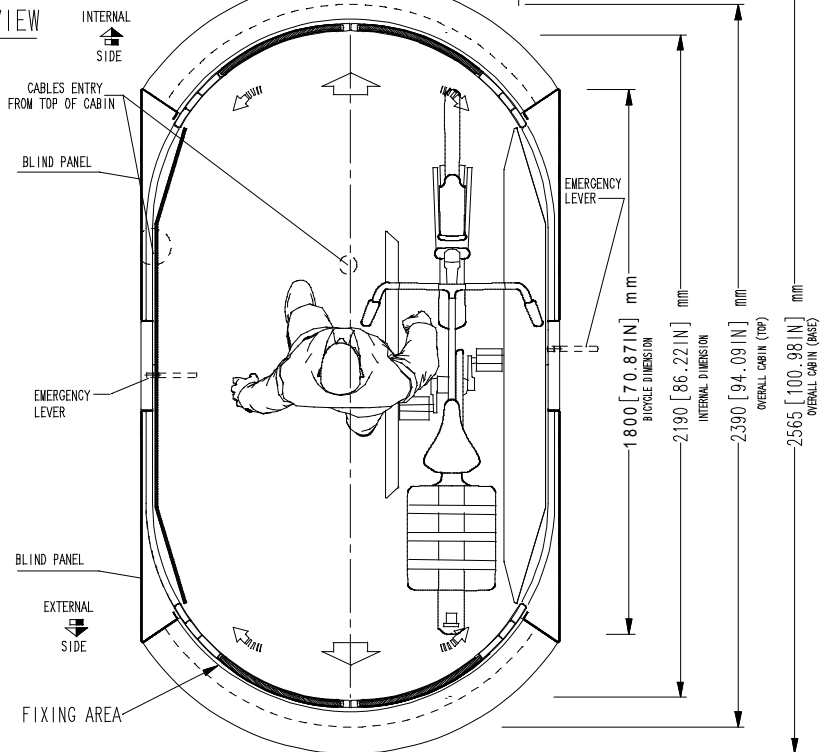

DETAIL "A"

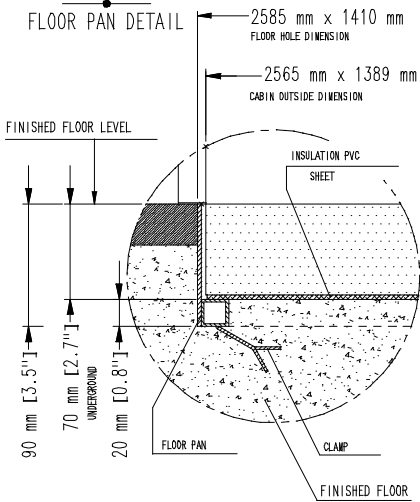

2	11/02/2016	IMPROVED DETAILS	ISABELLA
1	27/01/2016	CROSS SECTION VIEW ADDED	ISABELLA
REV	DATE	REVISION DESCRIPTION	DRAWN BY
DRAWN BY: ISABELLA		DESIGNED AND MANUFACTURED BY:	DISTRIBUTED BY:
DATE: 22/01/2016		 designed for your security	
DRAWING NUMBER: EARC326			
REVISION: 2	TITLE/DESCRIPTION		
SCALE: 1:25	D.I. BUSSOLA FPJ-140 2HP (BICICLETTA)		<i>Cabin recessed into the floor (ramp or floor pan required)</i>
PAGE 1 OF 1			<i>Overall dimensions and mechanical installation requirement</i>

THIS DOCUMENT IS AN ALLUSER INDUSTRIE PROPERTY AND IT CANNOT BE COPIED OR TRANSFERRED TO THIRD PARTIES WITHOUT A PREVIOUS WRITTEN AUTHORIZATION. DUE TO OUR POLICY OF CONTINUOUS PRODUCT DEVELOPMENT, ALL DIMENSIONS AND SPECIFICATIONS DESCRIBED IN THIS DOCUMENT ARE SUBJECT TO CHANGE WITHOUT NOTICE.