

FRONT VIEW

SECURE SIDE

NOTE:

CONSTRUCTION TOLERANCES:

- + 10 mm OVERALL FOR WIDTH
- +50 mm HEIGHT

INSTALLATION REQUIREMENT

SPACE FOR MAINTENANCE ABOVE TOP OF THE CABIN ON THE INTERNAL SIDE:

- \*MIN. 300 mm [11.81"]
- \*RECOMMENDED 750 mm [29.53"]

\*if space does not meet the required specifications contact us to discuss alternatives  
\*unit must be fixed into suitable frame and finished by others

NOTE:

- unit must be installed on to a level floor (suggested flatness tolerance: ±1 mm)
- coating option: 2 mm thickness in addition to size

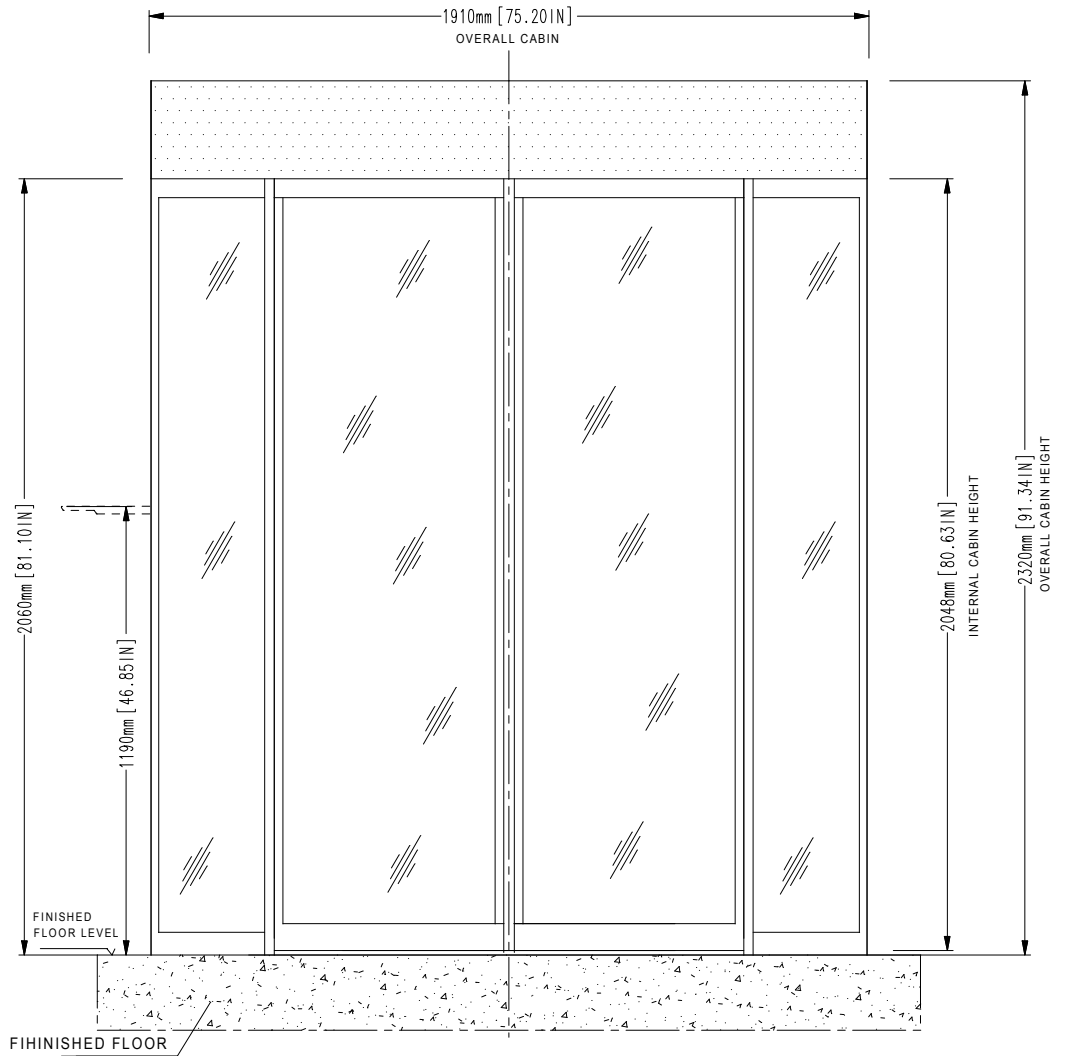

TOP VIEW

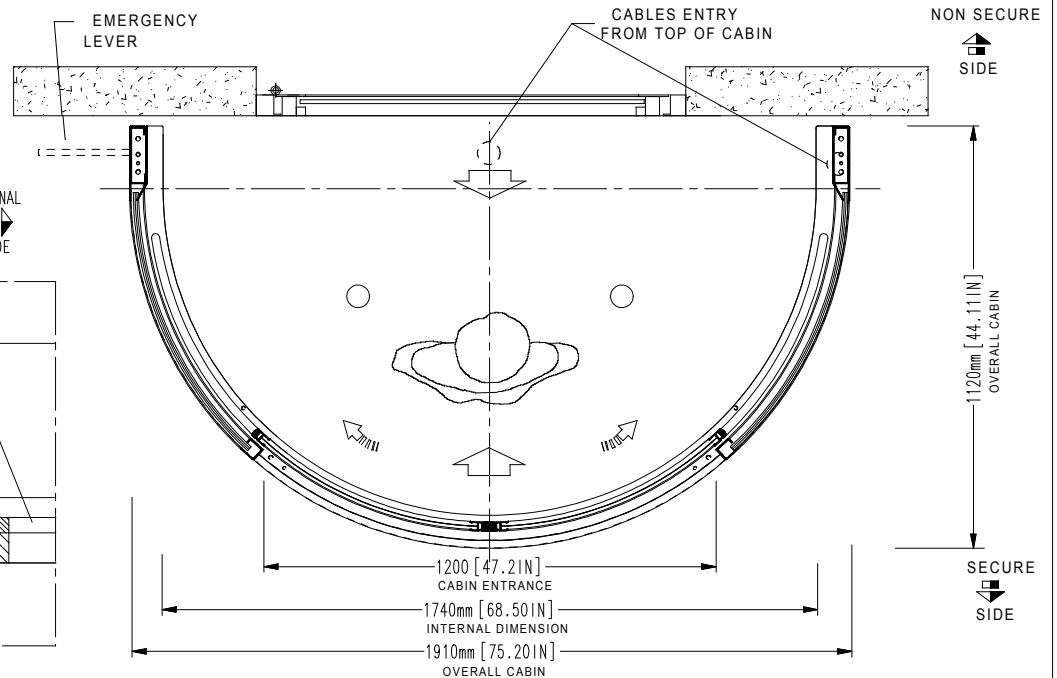

DETAIL 'A'

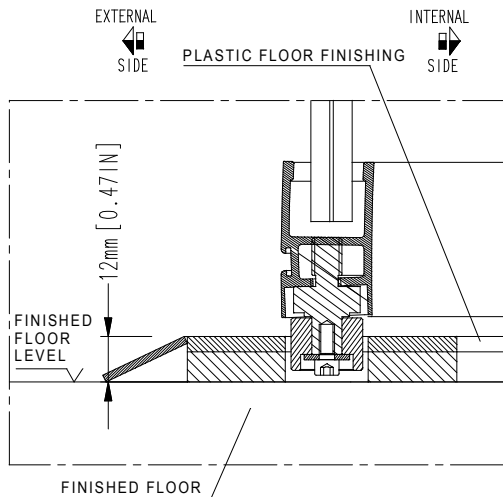

1	30/06/2017	UPDATED FONT	L.BERTAZZO
REV	DATE	REVISION DESCRIPTION	DRAWN BY
DRAWN BY: ISABELLA		DESIGNED AND MANUFACTURED BY: <b>aalluser</b> INDUSTRIE designed for your security	DISTRIBUTED BY:
DATE: 26/05/2017			
DRAWING NUMBER: EARC383			
REVISION: 1	TITLE/DESCRIPTION		<i>Flush mounted to floor (no recess required)</i> <i>Overall dimensions and mechanical installation requirement</i>
SCALE: 1:20	HPJ190 MY16 ENTRANCE = 1200 MM		
PAGE 1 OF 1			

THIS DOCUMENT IS AN ALLUSER INDUSTRIE PROPERTY AND IT CANNOT BE COPIED OR TRANSFERRED TO THIRD PARTIES WITHOUT A PREVIOUS WRITTEN AUTHORIZATION. DUE TO OUR POLICY OF CONTINUOUS PRODUCT DEVELOPMENT, ALL DIMENSIONS AND SPECIFICATIONS DESCRIBED IN THIS DOCUMENT ARE SUBJECT TO CHANGE WITHOUT NOTICE.