

**NOTE:**

**GENERAL CONSTRUCTION TOLERANCE: ± 5 mm [± 0.2"]**

**INSTALLATION REQUIREMENT**

**SPACE FOR MAINTENANCE ABOVE TOP OF THE CABIN ON THE INTERNAL SIDE:**  
 \*MIN. 300 mm [11.81"]  
 \*RECOMMENDED 750 mm [29.53"]

\*if space does not meet the required specifications contact us to discuss alternatives

**FRONT VIEW**  
**SECURE SIDE**

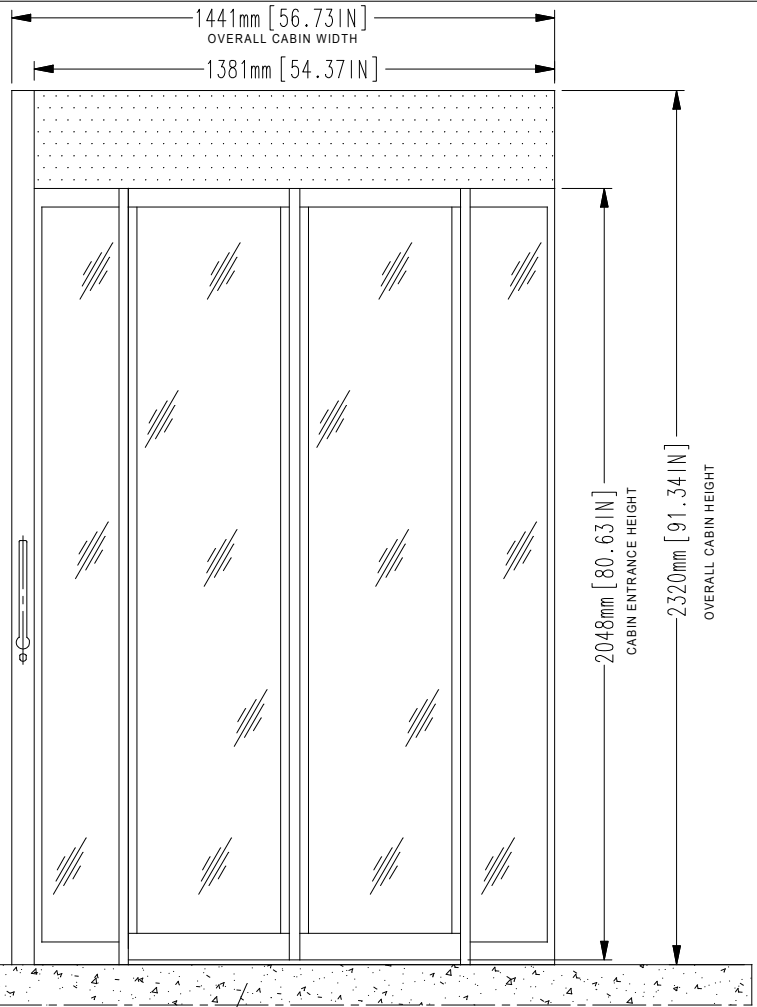

**DETAIL 'A'**

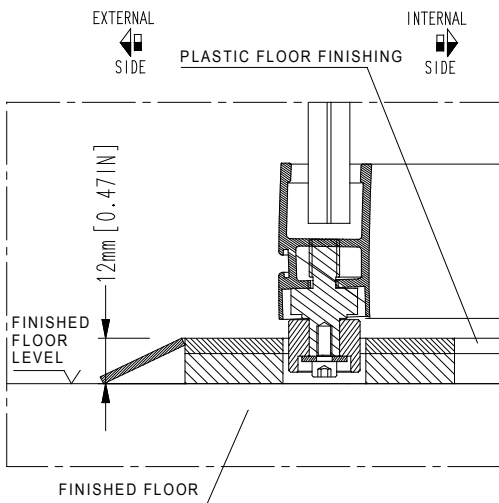

**TOP VIEW**

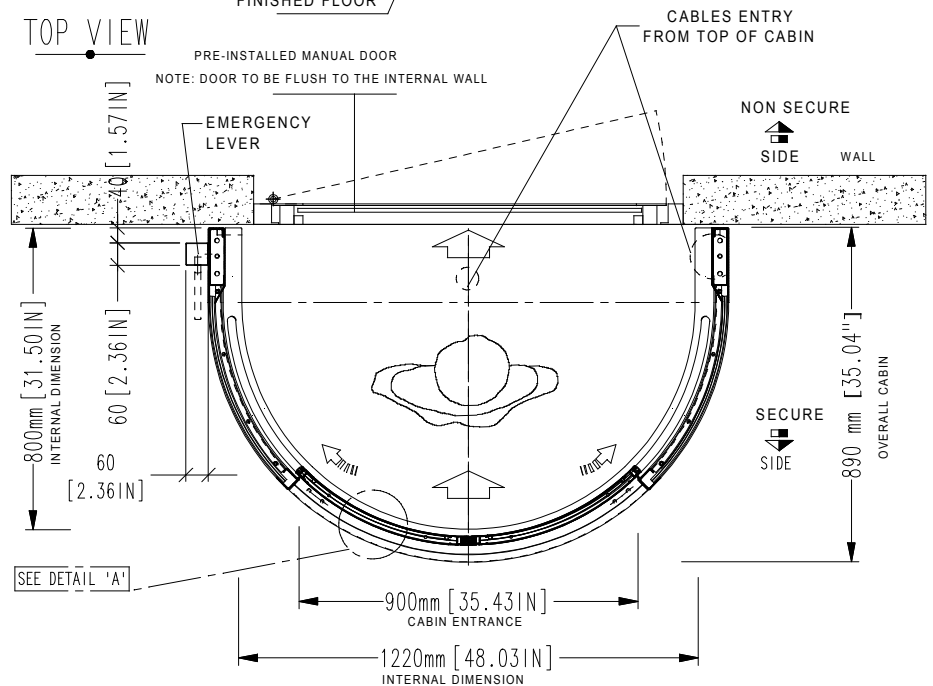

**NOTE:**

- unit must be installed on to a level floor (suggested flatness tolerance: ±1 mm)

- coating option: 2 mm thickness in addition to size

REV	DATE	REVISION DESCRIPTION	DRAWN BY
DRAWN BY: <b>ISABELLA</b>		DESIGNED AND MANUFACTURED BY:	DISTRIBUTED BY:
DATE: <b>10/07/2017</b>		<p>designed for your security</p>	
DRAWING NUMBER: <b>EARC391</b>			
REVISION: <b>0</b>		TITLE/DESCRIPTION	<b>Flush mounted to floor (no recess required)</b> <b>Overall dimensions and mechanical installation requirement</b>
SCALE: <b>1:20</b>		<b>HPJ140 MY16/EM. LEVER 90</b>	
PAGE 1 OF 1			

THIS DOCUMENT IS AN ALLUSER INDUSTRIE PROPERTY AND IT CANNOT BE COPIED OR TRANSFERRED TO THIRD PARTIES WITHOUT A PREVIOUS WRITTEN AUTHORIZATION. DUE TO OUR POLICY OF CONTINUOUS PRODUCT DEVELOPMENT, ALL DIMENSIONS AND SPECIFICATIONS DESCRIBED IN THIS DOCUMENT ARE SUBJECT TO CHANGE WITHOUT NOTICE.