

NOTE:

GENERAL CONSTRUCTION TOLERANCE: $\pm 5 \text{ mm}$ [± 0.2 "]

INSTALLATION REQUIREMENT

SPACE FOR MAINTENANCE ABOVE TOP OF THE CABIN ON THE INTERNAL SIDE:

*MIN. 300 mm [11.81"]

*RECOMMENDED 750 mm [29.53"]

*if space does not meet the required specifications contact us to discuss alternatives

FRONT VIEW
NON SECURE SIDE

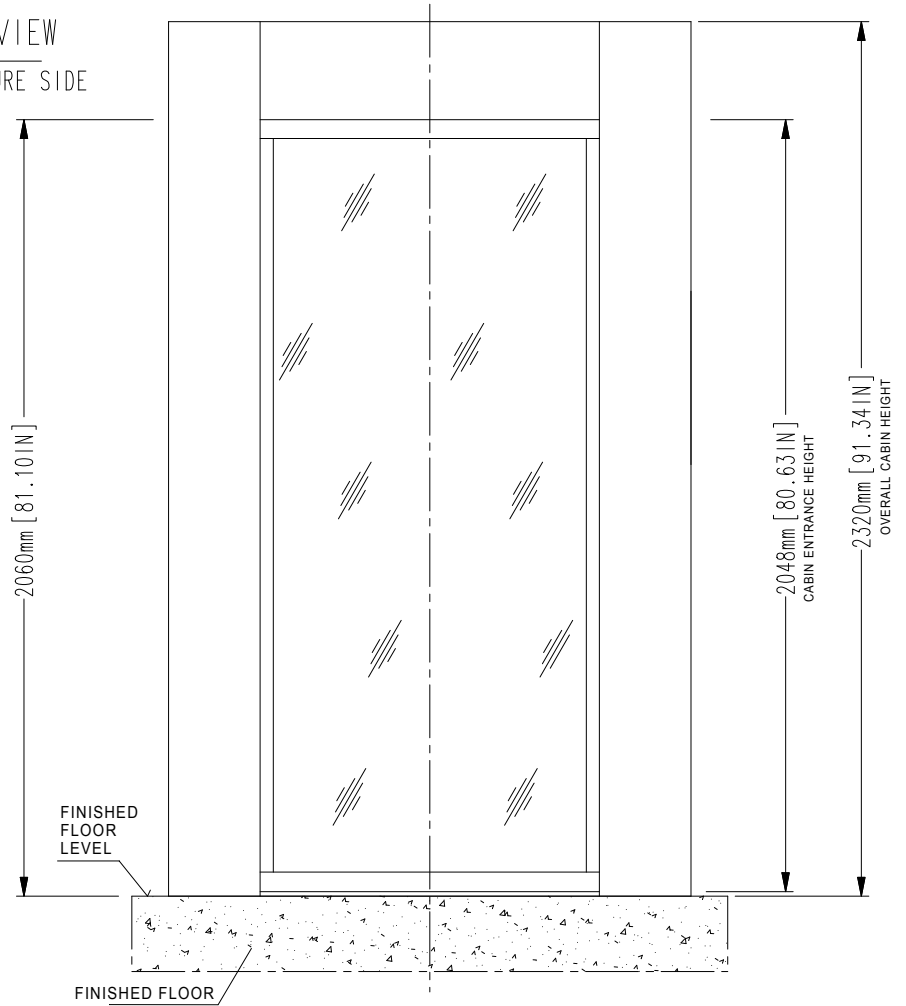

DETAIL 'A'

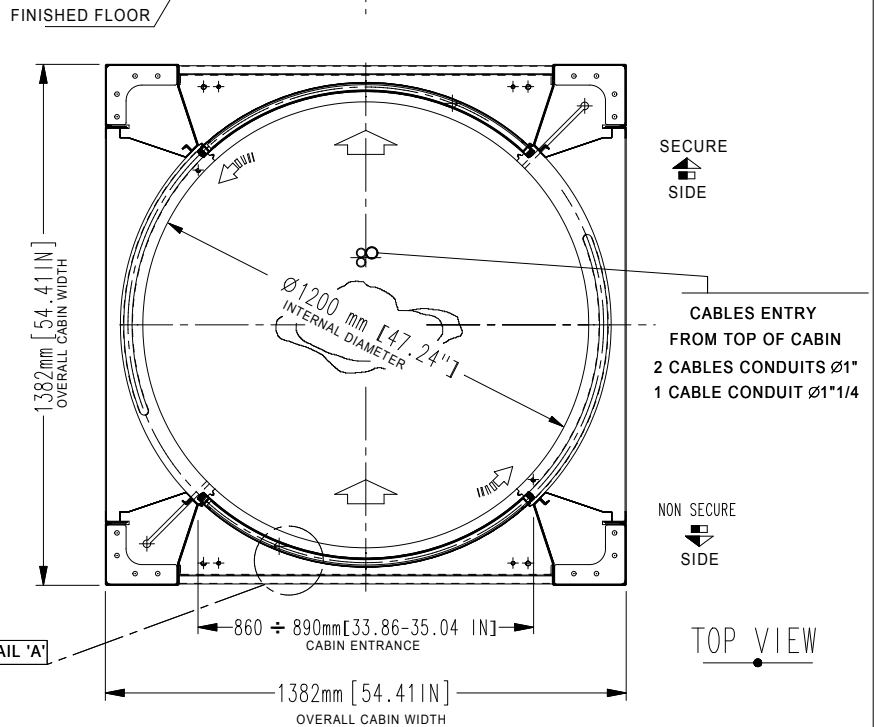
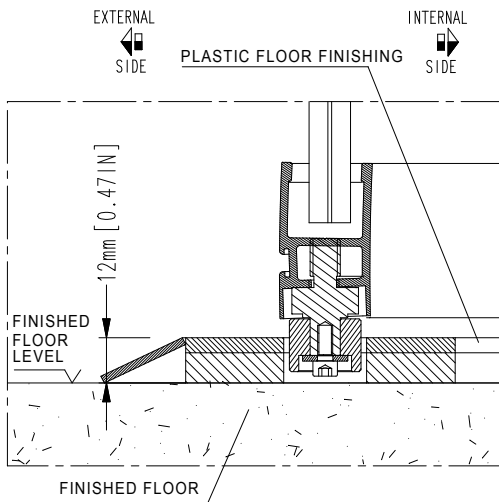

NOTE:

- unit must be installed on to a level floor (suggested flatness tolerance: $\pm 1 \text{ mm}$)

- coating option: 2 mm thickness in addition to size

| REV | DATE | REVISION DESCRIPTION | DRAWN BY |
|------------------------------|------------|------------------------------|---|
| 4 | 08/05/2018 | TOP VIEW MODIFIED | L.BERTAZZO |
| 3 | 09/11/2017 | OVERALL CABIN WIDTH MODIFIED | L.BERTAZZO |
| DRAWN BY: ISABELLA | | | DESIGNED AND MANUFACTURED BY: alluser INDUSTRIE designed for your security |
| DATE: 17/03/2016 | | | |
| DRAWING NUMBER: EARC351 | | | DISTRIBUTED BY: |
| REVISION: 4 | | | |
| SCALE: 1:20 | | | Flush mounted to floor (no recess required) Overall dimensions and mechanical installation requirement |
| PAGE 1 OF 1 | | | |
| TITLE/DESCRIPTION | | E3R-E3KR MY16/2 DOORS | |

THIS DOCUMENT IS AN ALLUSER INDUSTRIE PROPERTY AND IT CANNOT BE COPIED OR TRANSFERRED TO THIRD PARTIES WITHOUT A PREVIOUS WRITTEN AUTHORIZATION. DUE TO OUR POLICY OF CONTINUOUS PRODUCT DEVELOPMENT, ALL DIMENSIONS AND SPECIFICATIONS DESCRIBED IN THIS DOCUMENT ARE SUBJECT TO CHANGE WITHOUT NOTICE.